

RoughNeck® Stand

- 038A001 8.3 lbs (3.7 kg).
- 22-gauge steel desk with rolled edges for instrument protection and reinforcement.
- Trigger lock height adjustment mechanism adjusts height from 27" to 43³/₈" (69 to 110 cm) (desk lip to floor).
- Wobble-free base attachment.
- Bolt-through desk attachment.
- Durable black powder-coat paint finish.
- 20" x 12¹/₂" (51 x 30.5 cm) desk.
- GREENGUARD Indoor Air Quality Certified® and GREENGUARD Children & SchoolsSM Certified.
- Environmental attributes and LEED compliance for these products can be found at www.wengercorp.com/GREEN or by contacting your Wenger representative.
- Five-year warranty.

Accessories

The following music stand lights are available:

- Classic Electric Music Stand Light
- Duet LED Music Stand Light
- Duet II LED Music Stand Light
- Hammerhead LED Music Stand Light
- Encore LED Music Stand Light
- Orchestra LED Music Stand Light

See the Music Stand Lights Technical Sheet for details.

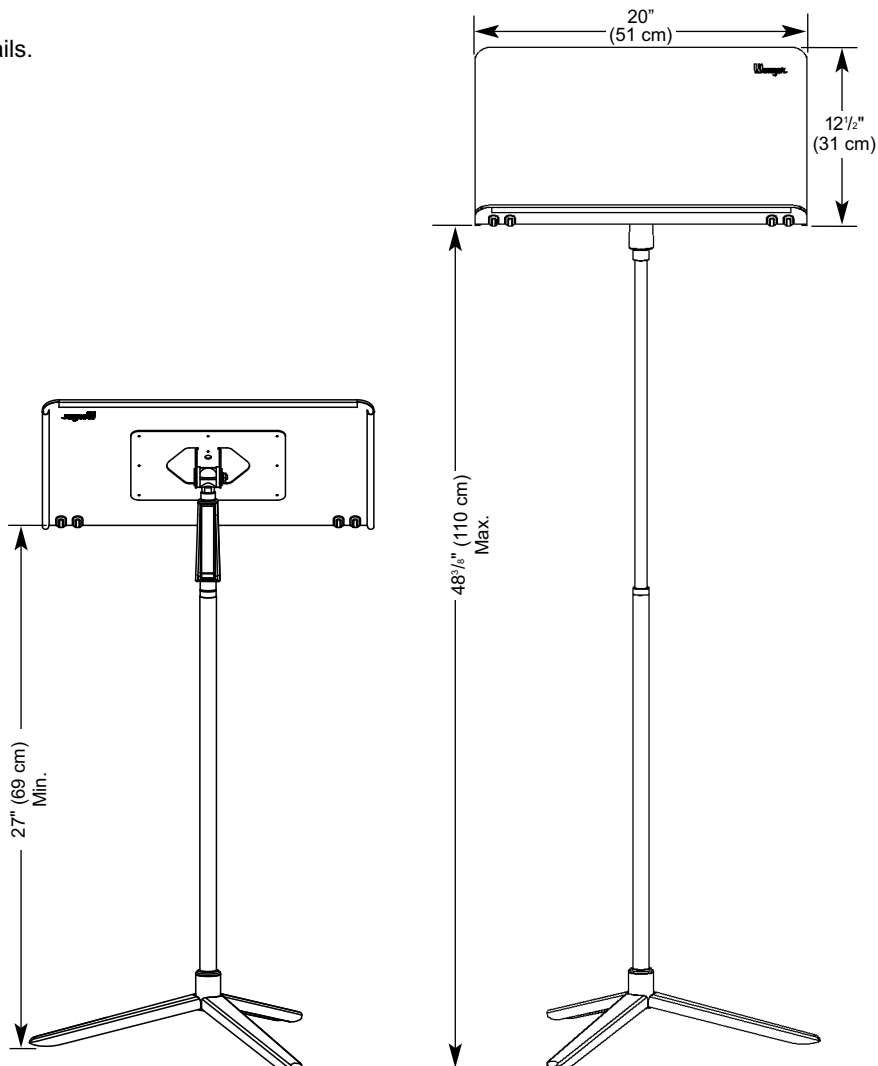
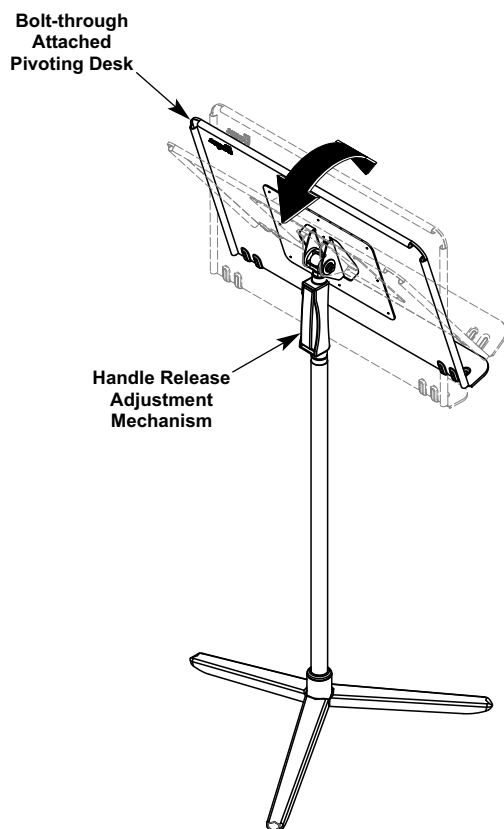

Accessories continued on next page.

Accessories (continued)

Large Stand Move and Store Cart

- 039C202 38 lbs (17 kg).
- Holds 20 RoughNeck® Stands.
- Large center pivot wheels for maneuverability.
- Loads and unloads from both ends.
- 14-gauge 1" x 1½" (2.5 x 4 cm) and 16-gauge 7/8" (2 cm) steel tubing with 8" (20 cm) wheels and 5" (13 cm) heavy-duty casters.
- Stores compactly in 27½" x 68" (70 x 173 cm) floor space. Allow 60" (153 cm) for height.

Small Stand Move and Store Cart

- 039D201 21 lbs (9.5 kg).
- Holds 10 RoughNeck® Stands.
- Two-wheel cart design allows transport up and down stairs.
- 14-gauge 1" x 1½" (2.5 x 4 cm) and 16-gauge 7/8" (2 cm) steel tubing with 8" (20 cm) heavy-duty wheels.
- Stores compactly in 27½" x 36" (70 x 91 cm) floor space. Allow 60" (153 cm) for height.

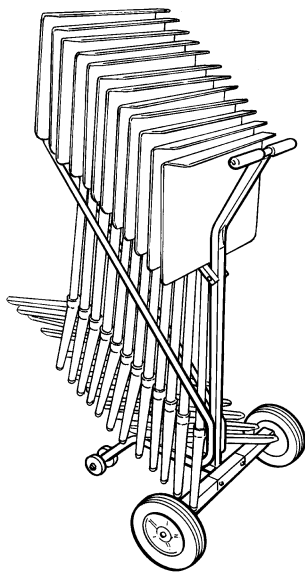

Small Move and Store Cart



Large Move and Store Cart

WENGER CORPORATION
555 Park Drive, PO Box 448
Owatonna, MN 55060-0448
Phone 800.4WENGER (493.6437)
Fax 507.455.4258
Customer Service 800.887.7145

WENGER CORPORATION
CANADIAN REPRESENTATIVE OFFICE
Phone 800.268.0148

WORLDWIDE
Phone 507.455.4100
Fax 507.774.8576

WEB SITE
wengercorp.com