

# Nota® Standard Chair

- 0330000 Black finish frame, 11 lbs (5 kg).
- 0330001 Chrome finish frame, 11 lbs (5 kg).
- Black powder-coat paint finish frame for maximum durability. Chrome finish frame is also available.
- Patented design provides two seating zones: "Engaged" (rear) and "Perched" (forward).
  - The engaged position allows the occupant to sit with a thigh to back angle of 97°.
  - The perched position allows the occupant to sit with a thigh to back angle in the range of 96-106°.
  - A transition area allows users to move seamlessly between zones.
- Each zone enhances performance by promoting a naturally balanced skeletal shape, reducing muscle strain and enabling increased circulation, freedom of movement, and diaphragmatic breathing.
- Narrow convex back provides lumbar support while still allowing for freedom and range of movement.
- Wear resistant polypropylene seat and back promote even weight distribution, greater comfort and a lasting appearance.
- Seat and back available in three colors: Black, Plum and Blue.
- Back is 1/8" (3 mm) thick.
- Seat is 9/64" (3.6 mm) thick.
- 14-gauge 7/8" (22 mm) welded round tube frame.
- Available in heights of 14.5" (368 mm), 16" (406 mm), 17.5" (445 mm), 19" (483 mm), 20.5" (521 mm).
- Rounded waterfall front allows one height of chair to accommodate a wider range of body sizes.
- Durable, specially designed floor glides provide stability when seated and ease of movement when arranging chairs.
- Chairs stack for compact storage, up to eighteen chairs on a cart; eight without a cart. If chairs are equipped with the Ganging Clamp Accessory, they can be stacked no more than six high.
- Specially designed stacking bumpers provide maximum stability and protection when chairs are stacked.
- ANSI/BIFMA x 5.1-2002.
- California Technical Bulletin 133 compliant.
- UL GREENGUARD Certified - Product certified for low chemical emissions: [ul.com/gg](http://ul.com/gg) - UL 2818.
- Environmental attributes and LEED compliance for this product can be found at [www.wengercorp.com/GREEN](http://www.wengercorp.com/GREEN) or by contacting your Wenger representative.
- Five-year warranty.

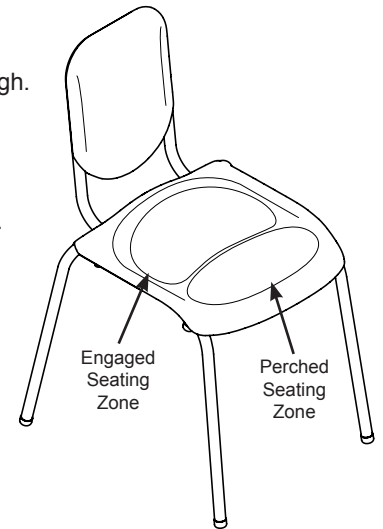
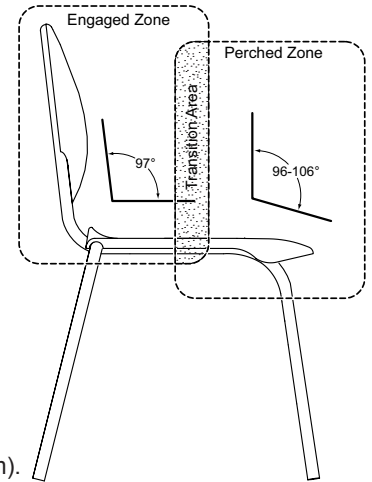

Chair Height	A*	B	C	D
14-1/2" (368 mm)	14-1/2" (368 mm)	19" (483 mm)	19-3/8" (492 mm)	29-1/8" (740 mm)
16" (406 mm)	16" (406 mm)	19" (483 mm)	20-1/8" (511 mm)	30-3/4" (781 mm)
17-1/2" (445 mm)	17-1/2" (445 mm)	19" (483 mm)	21" (533 mm)	32-1/4" (819 mm)
19" (483 mm)	19" (483 mm)	19" (483 mm)	21-5/8" (549 mm)	33-7/8" (860 mm)
20-1/2" (521 mm)	20-1/2" (521 mm)	19" (483 mm)	22-1/4" (565 mm)	35-3/8" (899 mm)

\*Dimension "A" measures frame height, not seat height.

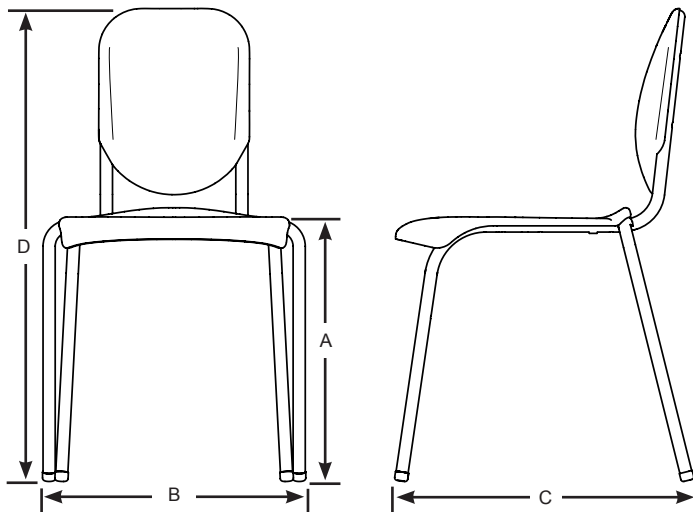
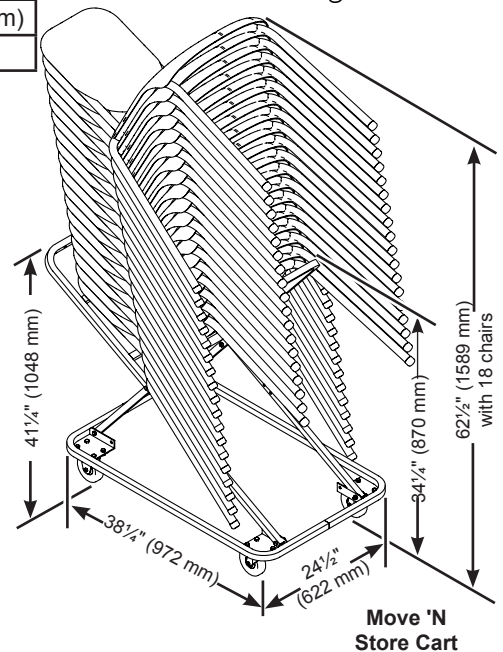

Move 'N Store Cart

## Accessories Include:

### Move 'N Store Cart

- 127A261 30 lbs (13.6 kg).
- Stack, move and store up to eighteen Nota Standard Chairs.
- 16-gauge steel construction with easy roll casters.

### Universal Folding Tablet Arm

- 0331010 5 lbs (2.3 kg).
- Can be set up for either right or left hand configuration.
- Choice of laminated surface colors: Graphite, Cherry, Fusion Maple and Solar Oak.
- 14" x 11-1/2" (356 x 292 mm) desk surface.
- Black polycarbonate desk tray.
- 14-gauge support assembly.
- Can be added at any time.
- Chairs cannot be stacked with this accessory attached.

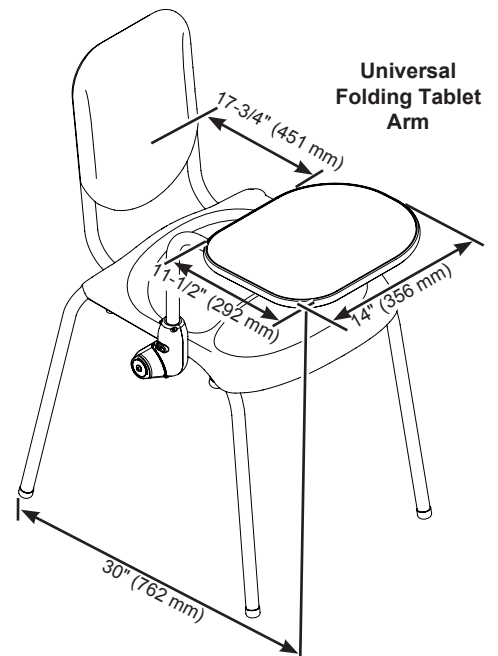

### Book & Music Storage Rack

- 190A066 2 lbs (1 kg).
- Mounts under chair.
- Black powder-coat paint finish for maximum durability.
- 3/16" diameter solid steel rod construction.
- Can be added at any time.
- Maximum storage weight: 30 lbs.
- Chairs cannot be stacked with this accessory attached.



### Tuba Rest

- 190A187 3 lbs (1.4 kg).
- Thru-bolted frame 16-gauge steel construction supports the full weight of the tuba.
- Height and depth adjustable.
- Vinyl protective coating.
- Can be added at any time.
- Chairs cannot be stacked with this accessory attached.

### Sousaphone Holder

- 190A184 11 lbs (5 kg).
- 14-gauge steel support frame and 16-gauge steel uprights.
- Supports and helps balance the sousaphone.
- Can be used for storage.
- Adjustable height.
- Vinyl protective coating.
- Can be added at any time.
- Chairs cannot be stacked with this accessory attached.

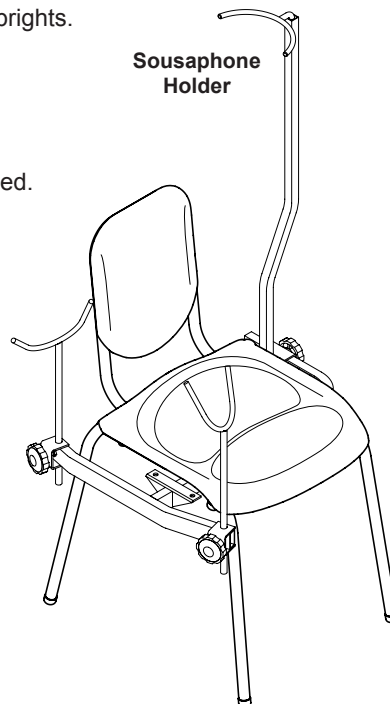

### Ganging Clamps

- 190A059.
- Molded polycarbonate.
- Used to connect chairs together.

### Dust Cover

- 054D500.
- Vinyl coated polypropylene.
- For use with chairs stacked on cart.

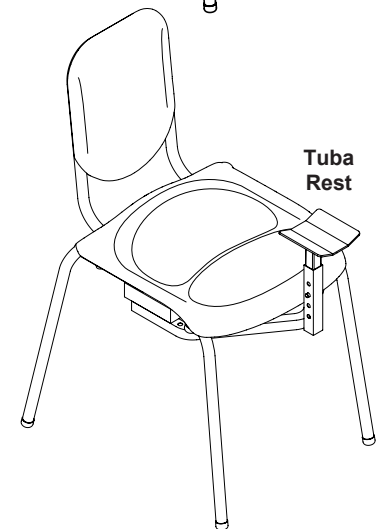

**Wenger**

**JRCLANCY**

**GEARBOSS**

© 2017 Wenger Corporation  
USA/2017-12/W



**WENGER CORPORATION**

Phone 800.4WENGER (493-6437) Worldwide +1.507.455.4100 | Fax 507.455.4258 Worldwide +1.507.774.8576  
Parts & Service 800.887.7145 | Canada Office 800.268.0148 | Web [wengercorp.com](http://wengercorp.com) | 555 Park Drive, PO Box 448 | Owatonna | MN 55060-0448

**JR CLANCY**

Phone 800.836.1885 Worldwide +1.315.451.3440 | Fax 877.836.1885 Worldwide +1.315.451.1766 | Web [jrclancy.com](http://jrclancy.com)  
7041 Interstate Island Road | Syracuse | NY 13209-9713

**GEARBOSS**

Phone 800.493.6437 | email [gearboss@wengercorp.com](mailto:gearboss@wengercorp.com) | Web [gearboss.com](http://gearboss.com) | 555 Park Drive, PO Box 448 | Owatonna | MN 55060-0448