

Classic 50® Stand

- 039E500 Standard Classic 50 Stand 4.9 lbs (2.2 kg).
- 039E499 Short Classic 50 Stand 4.8 lbs (2.2 kg).
- Lightweight, high-strength polycarbonate desk and base.
- Wobble-free base attachment.
- Black finish. Color molded through base and desk for long-lasting good looks.
- Bolt-through desk attachment to prevent desk from coming off unexpectedly.
- 13-1/2" x 20" (343 x 508 mm) Music Desk.
- Brass spring height adjustment mechanism
 - Standard Classic 50 Stand adjusts from 25" to 49" (635 to 1245 mm) (desk lip to floor).
 - Short Classic 50 Stand adjusts from 21" to 45" (534 to 1143 mm) (desk lip to floor).
- Available in shorter option for use with smaller musicians and when stand will be used primarily when seated.
- UL GREENGUARD Certified - Product certified for low chemical emissions: ul.com/gg - UL 2818.
- Environmental attributes and LEED compliance for these products can be found at www.wengercorp.com/GREEN or by contacting your Wenger representative.
- Five-year warranty.

Accessories

Electric Music Stand Light

Classic stand light fits all Wenger stands, and most other manufacturers' stands.

1090001 Music Stand Light, 14 oz. (0.4 kg)

LED Music Stand Lights

Compact, attractive, and adjustable, these battery-operated stand lights work with all Wenger stands.

Features all-LED technology, so no bulbs to replace.

237A040 HammerHead LED Music Stand Light, 2.1 oz (0.06 kg)

237A035 Encore LED Music Stand Light, 4.3 oz (0.12 kg)

237A033 Orchestra Music Stand Light, 10.2 oz (0.29 kg)

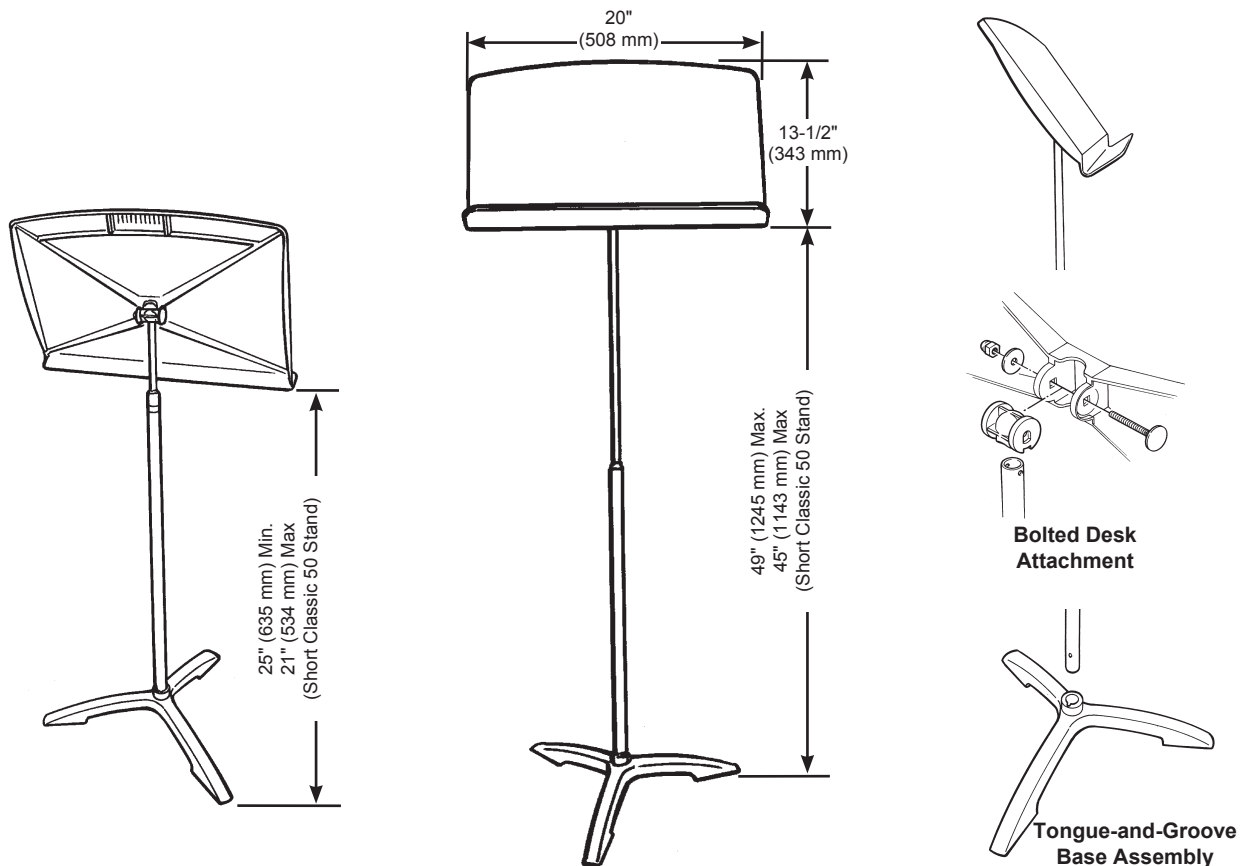

Accessories continued on next page.

Accessories (continued)

Hands-Free Page Turner

A rugged hands-free device for turning the pages on your digital sheet music. Simple setup and operation make this a great solution for musicians who need a hand.

040A142, 0.55 lbs (0.24 kg)

- Tap the foot switches to turn the pages on your digital sheet music forward or backward.
- No messy cables, connects wirelessly to tablets or computers up to 60' (1524 mm) away using secure Bluetooth technology.
- Internal rechargeable battery, up to 100 hours between charges.
- Nearly indestructible, made of same material as bullet-proof glass.



Hands-Free Page Turner

Universal Tablet Mount, Single

The perfect holder for most models of tablets. Clipping your tablet in place is easy and secure. No more resting your tablet on a stand, amp, floor, etc.

040A154, 15 oz (0.42 kg)

- Attaches to a standard 5/8" (16 mm) threaded stand or any music stand shaft using our Side Mount Extension.

Side-Mount Extension

Mount your tablet to the shaft of your music stand or mic stand.

040A140, 0.45 lbs (0.20 kg)

- Use your tablet with a traditional music stand or mic stand.
- Heavy duty steel extension bracket fits shafts up to 1" (25 mm) in diameter.
- Accepts our Universal Tablet Mount and other standard 5/8" (16 mm) threaded stand devices.
- 8" (203 mm) long with 6.25" (159 mm) extension from the shaft.

Large Stand Move and Store Cart

039C202, 38 lbs (17.2 kg).

- Holds twenty Classic 50 Stands.
- Large center pivot wheels for maneuverability.
- Loads and unloads from both ends.
- 14-gauge 1" x 1-1/2" (25 x 38 mm) and 16-gauge 7/8" (22 mm) steel tubing with 8" (203 mm) wheels and 5" (127 mm) heavy-duty casters.
- Stores compactly in 27-1/2" x 68" (699 x 1727 mm) floor space. Allow 61" (1550 mm) for height with Classic 50 Stands.

Small Stand Move and Store Cart

039D201 21 lbs (9.5 kg).

- Holds ten Classic 50 Stands.
- Two-wheel cart design allows transport up and down stairs.
- 14-gauge 1" x 1-1/2" (25 x 38 mm) and 16-gauge 7/8" (22 mm) steel tubing with 8" (203 mm) heavy-duty wheels.
- Stores compactly in 27-1/2" x 36" (699 x 915 mm) floor space. Allow 61" (1550 mm) for height with Classic 50 Stands.



(shown on traditional music stand)

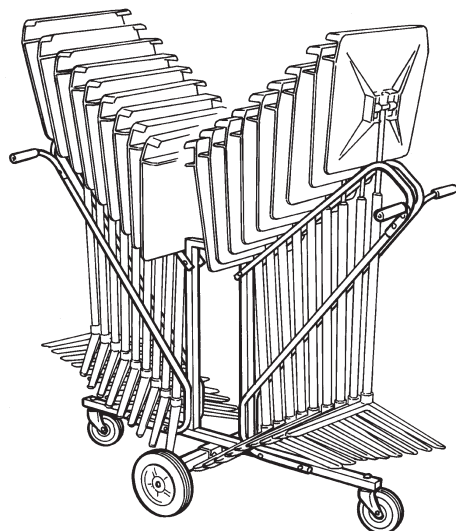

Large Move and Store Cart

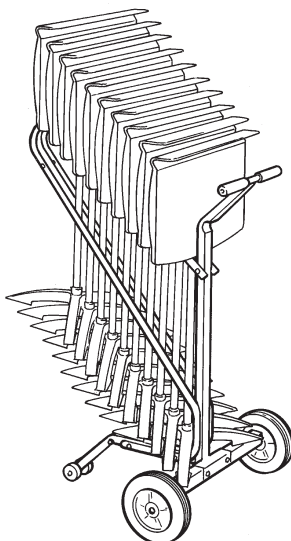

Small Move and Store Cart

Wenger®

JRCLANCY

GEARBOSS®

© 2017 Wenger Corporation
USA/2017-12/W



WENGER CORPORATION

Phone 800.4WENGER (493-6437) Worldwide +1.507.455.4100 | Fax 507.455.4258 Worldwide +1.507.774.8576
Parts & Service 800.887.7145 | Canada Office 800.268.0148 | Web wengercorp.com | 555 Park Drive, PO Box 448 | Owatonna | MN 55060-0448

JR CLANCY

Phone 800.836.1885 Worldwide +1.315.451.3440 | Fax 877.836.1885 Worldwide +1.315.451.1766 | Web jrclancy.com
7041 Interstate Island Road | Syracuse | NY 13209-9713

GEARBOSS

Phone 800.493.6437 | email gearboss@wengercorp.com | Web gearboss.com | 555 Park Drive, PO Box 448 | Owatonna | MN 55060-0448