

# Class Piano Workstation

- 225C024.\_ 56 lb (25 kg)
- Construction is 3/4" (19 mm) thick industrial grade composite wood with no added formaldehyde and polyester laminate finish in Wenger standard colors  
Edging is 1/8" (3 mm) radiused PVC
- Includes 20" wide x 11-1/2" high (508 x 292 mm) acrylic music holder
- Built-in 15 amp, 6-outlet power strip, UL listed
- Workstation measures 60" w x 18" deep x 5-1/4" high (1524 x 457 x 133 mm) and accommodates both left and right hand usage
- Pull-out computer keyboard tray adjusts for many different types of applications
- Rubber cupped feet attach firmly to most makes of digital pianos with a flat top surface
- Plastic cover to protect and conceal wiring is included
- Adjustable side panels to fit both 88 and 76-key free standing digital pianos
- Outside vertical supports have two adjustment positions at 52-1/4" and 46-11/16" (1327 and 1186 mm) wide to fit various electronic piano top profiles
- UL GREENGUARD Certified - Product certified for low chemical emissions: [ul.com/gg](http://ul.com/gg) - UL 2818
- Environmental attributes and LEED compliance for this product can be found at [www.wengercorp.com/GREEN](http://www.wengercorp.com/GREEN) or by contacting your Wenger representative
- Five-year warranty
- U.S. Patent D365,465

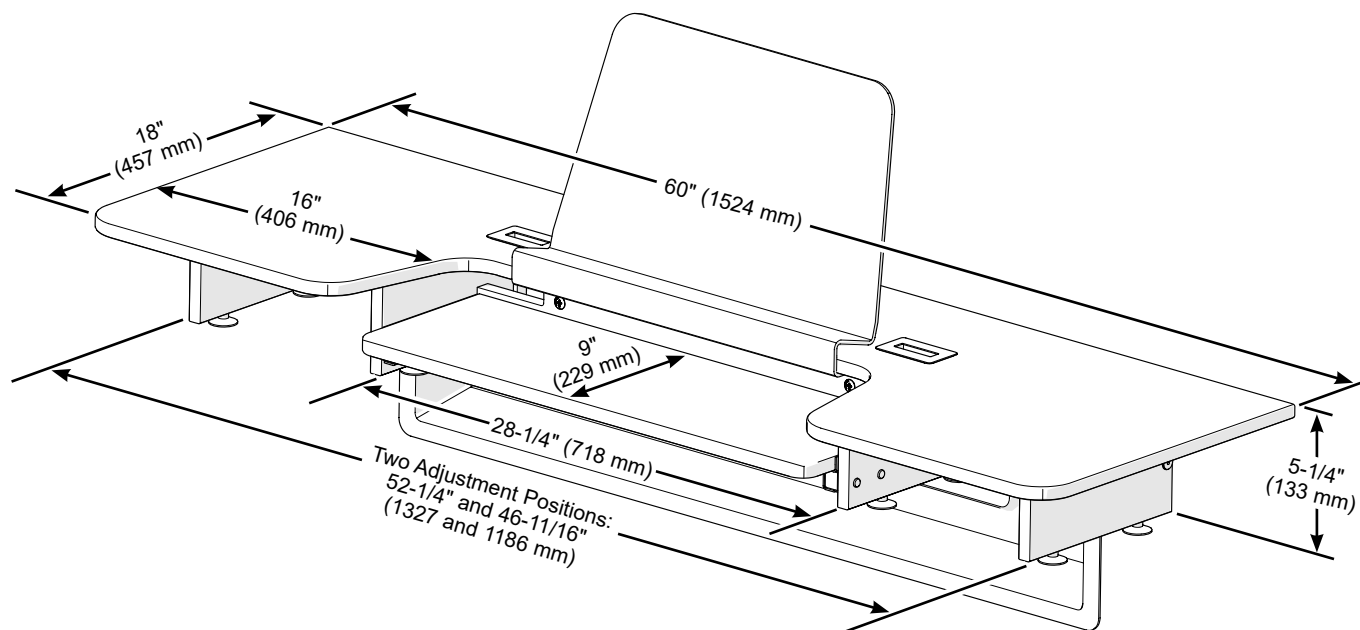

Wenger®

JRCLANCY

GEARBOSS®

PURCHASE  
ONLINE!© 2020 Wenger Corporation  
USA/2020-04

## MUSIC EDUCATION AND PERFORMING ARTS

Owatonna Office: Phone 800.4WENGER (493-6437) Worldwide +1.507.455.4100 | Parts & Service 800.887.7145 | [wengercorp.com](http://wengercorp.com)  
555 Park Drive, PO Box 448 | Owatonna | MN 55060-0448

Syracuse Office: Phone 800.836.1885 Worldwide +1.315.451.3440 | [jrclancy.com](http://jrclancy.com) | 7041 Interstate Island Road | Syracuse | NY 13209-9713

ATHLETICS Phone 800.493.6437 | email [gearboss@wengercorp.com](mailto:gearboss@wengercorp.com) | [gearboss.com](http://gearboss.com) | 555 Park Drive, PO Box 448 | Owatonna | MN 55060-0448